



承认书

SPECIFICATION FOR APPROVAL

文件编号 Document NO: ZM-JS-CRS24-0146

客户名称 Customer:			
客户零件编号 Customer part number:			
择明产品名称 ZEMING product name: 电流互感器 Current Transformer			
择明产品型号 ZEMING Product number: ZMXQD08A			
文件发布日期 Document release date: 2024-03-22			
文件有效期 File validity period: 长期 long time			
版本号 Version number: A1			
择明审批确认 ZEMING Approval and verification			客户确认(签字或盖章均有效) Customer confirmation(sign or stamp)
批准 Approval	审核 Audit	编制 Draw up	确认人 Confirmer: 日期 Date:
高媛	赵玉霞	朱旭	
特别申明: 1.此技术保证书请客户在 7 个工作日内确认回复, 若在规定的时间内未答复, 择明将视为同意。This is Technical Guarantee. Please customer confirm it and reply within 7 working days. And if it not be replied within the prescribed time, ZEMING will deem that customer has agreed it. 2.本技术协议为客供各执一份, 客户端为原件。客户端确认后, 也可以将此转换为自己控制协议, 但内部协议条款不允许修改变动.This technical agreement is in duplicate,supplier holding one copy and customer holding the original copy. After being confirmed by customer,this agreement can also transform to be internal control agreement,but the terms of this agreement can not be allowed to modify changes. 3.双方确认后均需按照协议里面之相关要求来进行控制,有违协议要求的导致 产品问题,需己方自行承担。After confirmed by both parties,it shall be carried out in according to the requirements of agreement. And against this agreement,it caused any products' problem,to duty party own bear. 4.客供双方提出变更必须使用此文件作为变更主页(可带附页)。 This document must be used as main or home page of changes(can be with attached pages) when both parties propose changes.			





电流互感器规格书 current transformer specification

1. 尺寸 Size

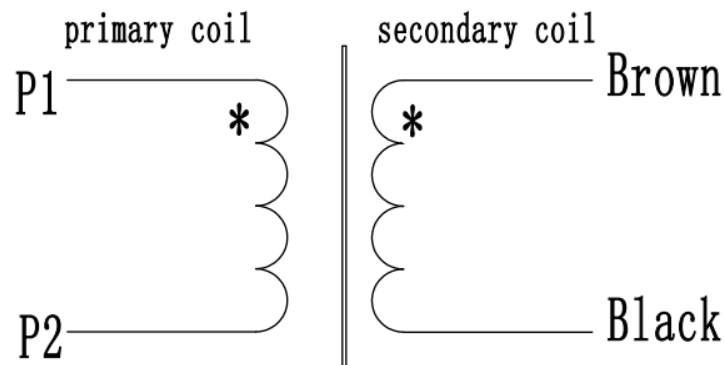
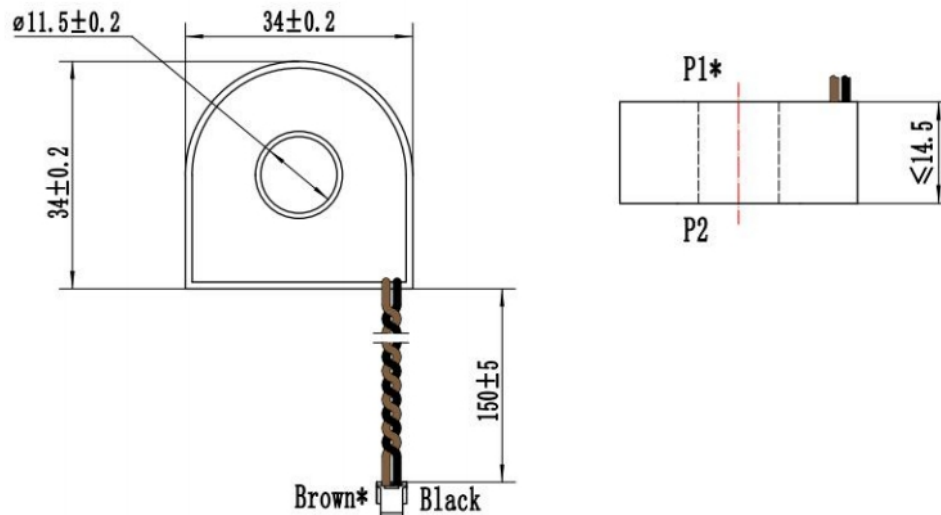

备注 Notes:

- 1) Unit 单位: mm
- 2) Current direction 电流方向: “*” 代表 “同名端”-- “*” means “same Polarity”;



2. 特性参数 characteristic parameters:

参数 Characteristics	数值 Values
工作频率 Operating frequency	50/60Hz
工作温度 Operating temperature	-40°C ~+ 85°C
相对湿度 Relative humidity	≤95%
额定一次电流 Rated primary current I_p	5A
最大一次工作电流 Maximum primary operating current I_{max}	100A
抗直流精度 Testing current for DC component 100A/Root 2	< ± 3.0%
额定二次电流 Rated second current	2mA
变比 Transformation ratio	2500:1
负载电阻 User supplied burden resistor	10Ω
绝缘耐压测试 Insulation withstand voltage test	4Kv/1min < 1mA
绝缘电阻 Insulation resistance	>1000MΩ/500Vdc
精度等级 Accuracy class	0.5class

Add: Dabogeliu village, Jinniu Town, Qingxian, Cangzhou City, Hebei Province, China. 062650

河北省沧州市青县金牛镇大鹁鸽留工业园, 邮编: 062650

Tel: 86-25-52601870

mail: zm@zeming-e.com

Website: www.micro-transformer.com



3. BOM 明细表 BOM List

编号 No.	材料 Material	规格 Spec. model	UL 编码 UL code	制造商 Manufacturer
1	铁芯 Core	纳米晶铁芯 Nano Core	/	河北凯瑞思电子科技有限公司 Hebei kairuisi electronic technology co., ltd
2	漆包线 Winding	2UEW	E206822	无锡巨丰复合线有限公司 Wuxi jufeng composite line co., ltd
3	外壳 Outside shell	PBT, Black	E59481	长春塑料 CHANGCHUN PLASTICS CO.,LTD
4	环氧树脂 Epoxy resin	TXH-92H-8	E196959	天津津桥 TIANJIN XINQIAO INSULATING MATERIAL CO
5	引线 Leading wires	UL10368, 26AWG Brown&Black	E332522	东莞丹阳 DONGGUAN DANYANG Electronic Wire Co.,Ltd
6	胶带 Tape	阻燃环保 Flame retardant, Environmental protection	E328315	深圳新华辉 SHENZHEN XINHUAHUI
7	焊锡 Tin	Lead free high temperature 无铅高温	/	甲品 JIA PING
8	连接器 Connector	ZH1.5	E364711	浙江联和电子有限公司 Zhejiang Lianhe Electronics Co., Ltd

Add: Dabogeliu village, Jinniu Town, Qingxian, Cangzhou City, Hebei Province, China. 062650

河北省沧州市青县金牛镇大鹁鸽留工业园, 邮编: 062650

Tel: 86-25-52601870

mail: zm@zeming-e.com

Website: www.micro-transformer.com